

### Phase Control Circuit – Load Current Feedback Applications

**Technology:** Bipolar

#### Features

- Externally controlled integrated amplifier
- Variable soft start
- Automatic retriggering
- Voltage and current synchronisation
- Triggering pulse typ. 125 mA
- Internal supply voltage monitoring
- Temperature constant reference source
- Current requirement  $\leq 3$  mA

**Case:** DIP 14, SO 16

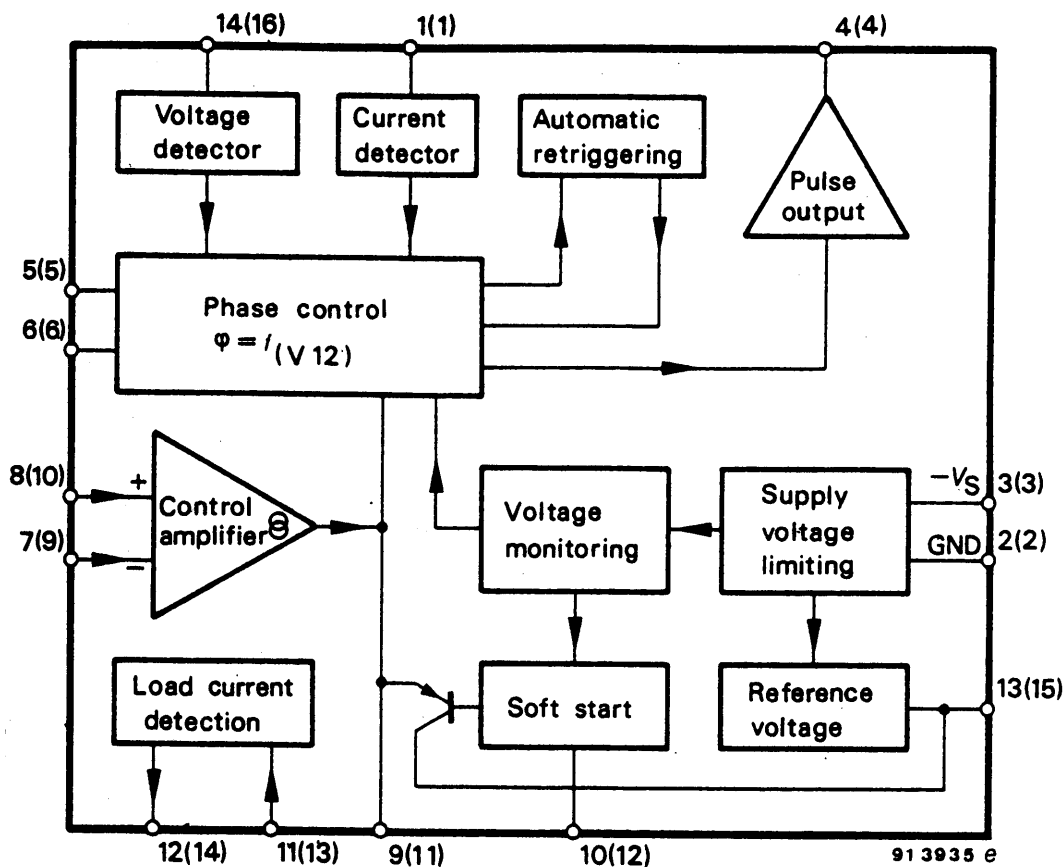

SO 16 in bracket  
(7, 8) N.C.

Figure 1 Block diagram

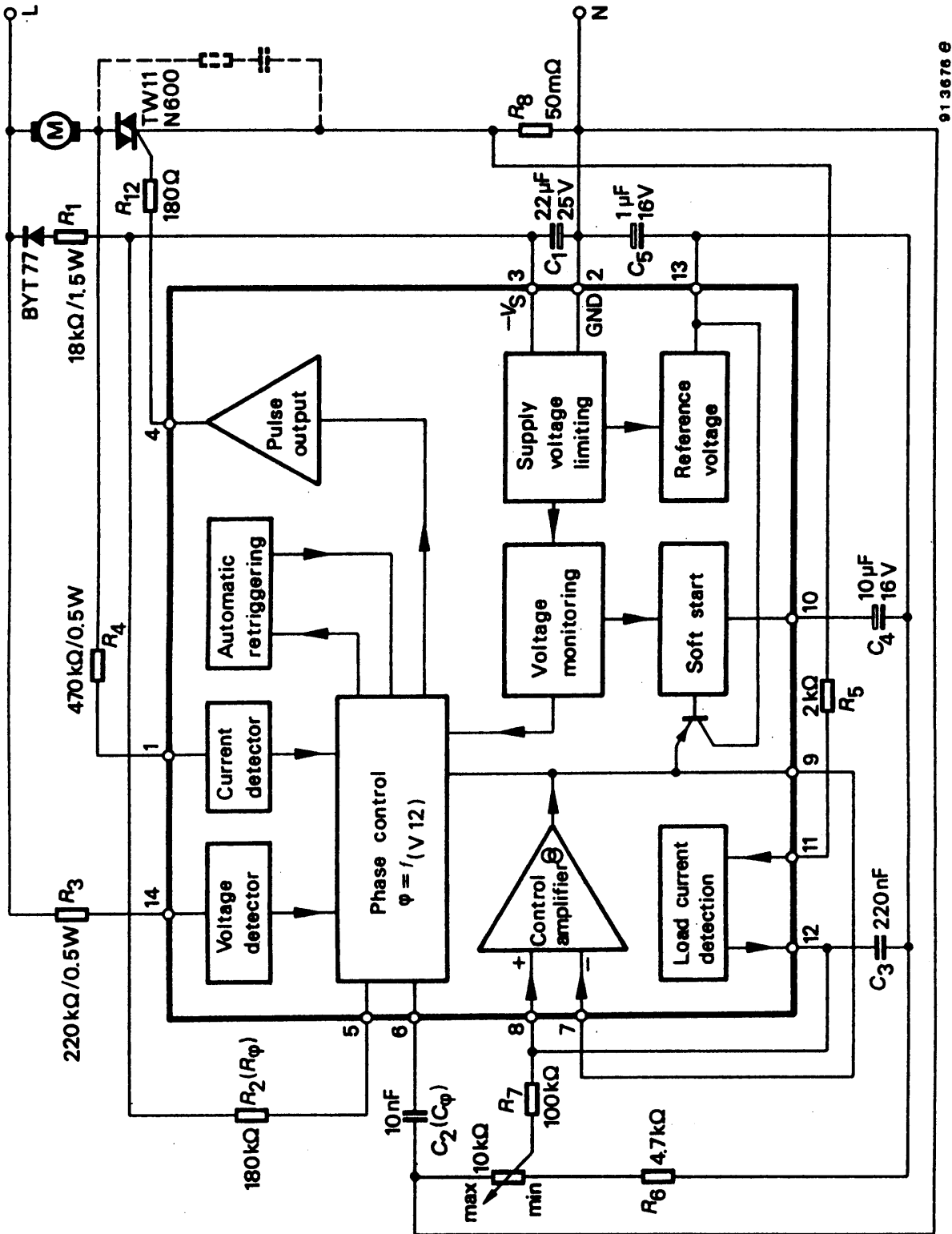

Figure 2 Block diagram with external circuitry  
Open loop control with load current compensation

### Description

#### Mains supply

The U 210 B is fitted with voltage limiting and can therefore be supplied directly from the mains. The supply voltage between Pin 2 (+pol/⊥) and Pin 3 builds up across  $D_1$  and  $R_1$  and is smoothed by  $C_1$ . The value of the series resistance can be approximated using:

$$R_1 = \frac{V_M - V_S}{2 I_S}$$

Further information regarding the design of the mains supply can be found in the data sheets in the appendix. The reference voltage source on Pin 13 of typ.  $-8.9\text{ V}$  is derived from the supply voltage. It represents the reference level of the control unit. Operating using an externally stabilised DC voltage is not recommended.

If the supply cannot be taken directly from the mains because the power dissipation in  $R_1$  would be too large, then the circuit shown in the following Figure 3 should be employed.

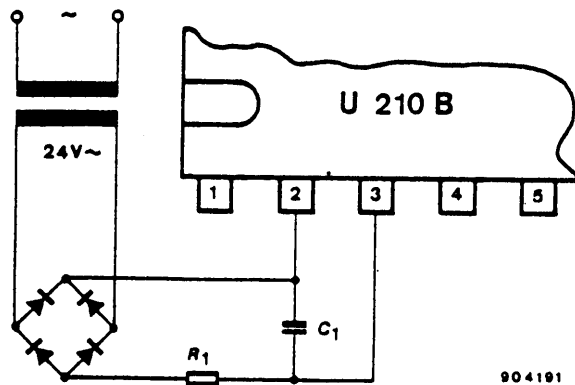

Figure 3 Supply voltage for high current requirements

#### Phase control

The function of the phase control is largely identical to that of the well known components U 111 B and TEA 1007. The phase angle of the trigger pulse is derived by comparing the ramp voltage, which is mains synchronised by the voltage detector, with the set value on the control input Pin 9. The slope of the ramp is determined by  $C_2$  and its charging current. The charging current can be varied using  $R_2$  on Pin 5. The maximum phase angle  $\alpha_{\max}$  can also be adjusted using  $R_2$ .

When the potential on Pin 6 reaches the nominal value predetermined at Pin 9, then a trigger pulse is generated whose width  $t_p$  is determined by the value of  $C_2$  (the value of  $C_2$  and hence the pulse width can be evaluated by assuming  $8\ \mu\text{s/nF}$ ). At the same time, a latch is set, so that as long as the automatic retriggering has not been activated, then no more pulses can be generated in that half cycle.

The current sensor on Pin 1 ensures that, for operation with inductive loads, no pulse will be generated in a new half cycle as long as current from the previous half cycle is still flowing in the opposite direction to the supply voltage at that instant. This makes sure that "Gaps" in the load current are prevented.

The control signal on Pin 9 can be in the range  $0\text{ V}$  to  $-7\text{ V}$  (reference point Pin 2).

If  $V_{\text{pin}9} = -7\text{ V}$  then the phase angle is at maximum  $= \alpha_{\max}$  i.e. the current flow angle is a minimum. The minimum phase angle  $\alpha_{\min}$  is when  $V_{\text{pin}9} = V_{\text{pin}2}$ .

#### Voltage monitoring

As the voltage is built up, uncontrolled output pulses are avoided by internal voltage surveillance. At the same time, all of the latches in the circuit (phase control, soft start) are reset and the soft-start capacitor is short circuited. Used with a switching hysteresis of  $300\text{ mV}$ , this system guarantees defined start-up behaviour each time the supply voltage is switched on or after short interruptions of the mains supply.

### Soft-start

As soon as the supply voltage builds up ( $t_1$ ), the integrated soft-start is initiated. The figure below shows the behaviour of the voltage across the soft-start capacitor and is identical with the voltage on the phase control input on Pin 9. This behaviour allows a gentle start-up for the motor.

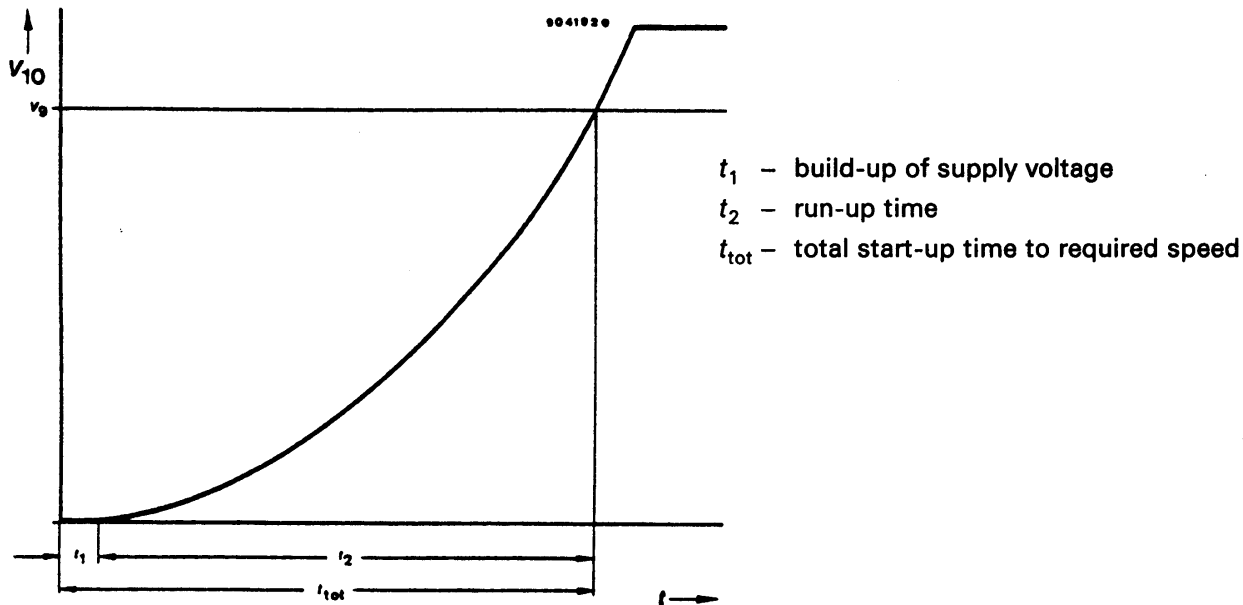

Figure 4 Soft-start

$C_3$  is first charged with typ.  $30 \mu\text{A}$ . The charging current then increases as the voltage across  $C_4$  increases giving a progressively rising charging function with more and more strongly accelerates the motor with increasing rotational speed. The charging function determines the acceleration up to the set point. The charging current can have a maximum value of  $85 \mu\text{A}$ .

### Control amplifier

The integrated control amplifier with differential input has a bipolar current output, with typically  $\pm 110 \mu\text{A}$  at Pin 9 and a transmittance of typ.  $1000 \mu\text{A/V}$ . The amplification and frequency response are determined by external circuit. For operation as a power control, it should be connected with Pin 7. Phase angle of the firing pulse can be adjusted by using the voltage at Pin 8. An internal limiting circuit prevents the voltage on Pin 9 becoming more negative than  $V_{13} + 1 \text{V}$ .

### Load current detection, Figure 2

Voltage drop across  $R_8$ , dependent of load current, generates an input-current at Pin 11 limited by  $R_5$ . Proportional output current of  $0.44 \times I_{11}$  (CTR) is available at Pin 12. It is proportional with respect to phase and amplitude of load current.

Capacitor  $C_3$  integrates the current whereas resistor  $R_7$  evaluates it. The voltage obtained due to load current proportionality, can be used according to the application i.e., load current compensation or load current regulation.

### Pulse output stage

The pulse output stage is short circuit protected and can typically deliver currents of  $125 \text{mA}$ . For the design of smaller triggering currents, the function  $I_{GT} = f(R_{GT})$  has been given in the data sheets in the appendix. In contrast to the U 111 B and the TEA 1007, the pulse output stage of the U 210 B has no gate bypass resistor.

### Automatic retriggering

The automatic retriggering prevents half cycles without current flow, even if the triac is turned off earlier e.g. due to not exactly centred collector (brush lifter) or in the event of unsuccessful triggering. After a time lapse of  $t_{pp} = 4.5 t_p$  is generated another triggering pulse which is repeated until either the triac fires or the half cycle finishes.

### General hints and explanation of terms

To ensure safe and trouble-free operation, the following points should be taken into consideration when circuits are being constructed or in the design of printed boards.

- The connecting lines from  $C_2$  to Pin 6 and Pin 2 should be as short as possible, and the connection to Pin 2 should not carry any additional high current such as the load current. When selecting  $C_2$ , a low temperature coefficient is desirable.

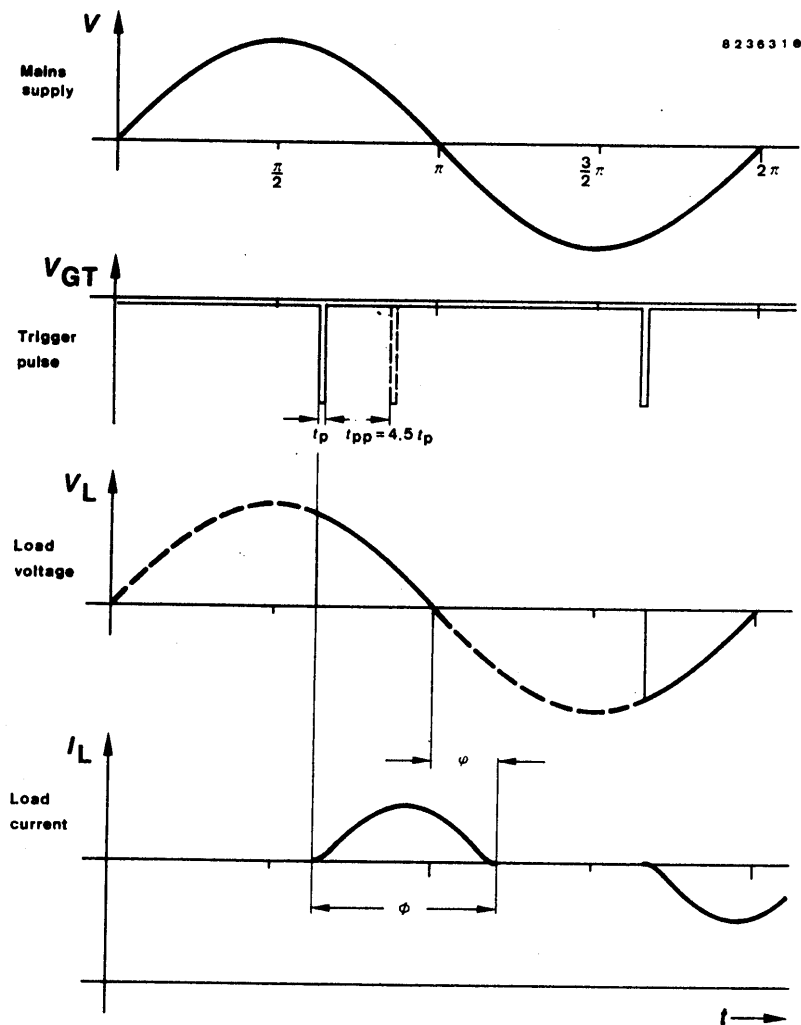

Figure 5 Explanation of terms in phase relationship

### Absolute Maximum Ratings

Reference point Pin 2, unless otherwise specified

Parameters		Symbol	Value	Unit
Current requirement	Pin 3	$-I_S$	30	mA
Peak current requirement	$t \leq 10 \mu s$ Pin 3	$-i_s$	100	mA
Synchronisation current	Pin 1	$-I_{sync.I}$	5	mA
	Pin 14	$-I_{sync.V}$	5	mA
	$t \leq 10 \mu s$ Pin 1	$-i_I$	35	mA
	$t \leq 10 \mu s$ Pin 14	$\pm i_V$	35	mA
<b>Load current monitoring</b>				
Input current	Pin 11	$-I_I$	2	mA
	$t \leq 10 \mu s$ Pin 11	$-I_I$	5	mA
<b>Phase control</b>				
Input voltage	Pin 9	$-V_I$	0 ... 7	V
Input current	Pin 9	$\pm I_I$	500	$\mu A$
	Pin 5	$-I_I$	1	mA
<b>Soft-start</b>				
Input voltage	Pin 10	$-V_I$	$ V_{13}  \dots 0$	V
<b>Pulse output</b>				
Reverse voltage	Pin 4	$V_o$	$V_S \dots 5$	V
<b>Amplifier</b>				
Input voltage	Pin 8	$V_I$	0 ... $V_S$	V
	Pin 7	$-V_I$	$ V_{13}  \dots 0$	
<b>Reference voltage source</b>				
Output current	Pin 13	$I_o$	7.5	mA
Storage temperature range		$T_{stg}$	-40 ... +125	$^{\circ}C$
Junction temperature		$T_j$	125	$^{\circ}C$
Ambient temperature range		$T_{amb}$	-10 ... +100	$^{\circ}C$

### Thermal Resistance

Parameters		Symbol	Maximum	Unit
Junction ambient	DIP 14	$R_{thJA}$	120	K/W
	SO 16 on p.c.	$R_{thJA}$	180	K/W
	SO 16 on ceramic	$R_{thJA}$	100	K/W

### Electrical Characteristics

$-V_S = 13.0 \text{ V}$ ,  $T_{\text{amb}} = 25 \text{ }^\circ\text{C}$ , reference point Pin 2, unless otherwise specified

Parameters	Test Conditions / Pin	Symbol	Min	Typ	Max	Unit
Supply voltage for mains operations	Pin 3	$-V_S$	13.0		$V_{\text{Limit}}$	V
Supply voltage limitation	$-I_S = 3 \text{ mA}$ Pin 3	$-V_S$	14.6		16.6	V
	$-I_S = 30 \text{ mA}$ Pin 3	$-V_S$	14.7		16.8	V
DC supply current	$-V_S = 13.0 \text{ V}$ Pin 3	$-I_S$	1.2	2.5	3.0	mA
Reference voltage source	$-I_L = 10 \text{ } \mu\text{A}$ Pin 13	$-V_{\text{Ref}}$	8.6	8.9	9.2	V
	$-I_L = 5 \text{ mA}$ Pin 13	$-V_{\text{Ref}}$	8.3		9.1	V
Temperature coefficient	Pin 13	$-TC_{V_{\text{Ref}}}$		0.5		mV/K
<b>Voltage monitoring</b>						
Turn-on threshold	Pin 3	$-V_{\text{SON}}$		11.2	13.0	V
Turn-off threshold	Pin 3	$-V_{\text{SOFF}}$	9.9	10.9		V
<b>Phase control currents</b>						
Current synchronisation	Pin 1	$I_{\text{sync.I}}$	0.35		3.5	mA
Voltage synchronisation	Pin 14	$I_{\text{sync.V}}$	0.35		3.5	mA
Voltage limitation	$\pm I_L = 5 \text{ mA}$ Pin 1	$\pm V_I$	8.0	8.9	9.5	V
	Pin 14	$\pm V_I$	8.0	8.9	9.5	V
<b>Reference ramp</b>						
Load current, Figure 6	$I_6 = f(R_f)$ $R_f = 1 \text{ K} \dots 820 \text{ K}\Omega$ Pin 6	$I_6$	1		20	$\mu\text{A}$
$R_\varphi$ -reference voltage	$\alpha \geq 180^\circ$ Pin 5,3	$V_{\varphi\text{Ref}}$	1.06	1.13	1.18	V
Temperature coefficient	Pin 5	$TC_{V_{\varphi\text{Ref}}}$		0.5		mV/K
<b>Pulse output, Figure 12</b>						
Output pulse current	$R_{\text{GT}} = 0$ , $V_{\text{GT}} = 1.2 \text{ V}$ Pin 4	$I_o$	100	125	150	mA
Reverse current	Pin 4	$I_{\text{or}}$		0.01	3.0	$\mu\text{A}$
Output pulse width	$C_\varphi = 10 \text{ nF}$ Pin 4,2	$t_p$		80		$\mu\text{s}$
<b>Automatic retriggering</b>						
Repetition rate	Pin 4	$t_{\text{pp}}$	3	4.5	6	$t_p$
<b>Amplifier</b>						
Common mode voltage range	Pin 7,8	$V_{7,8}$	$V_{13}$		-1	V
Input bias current	Pin 8	$I_{\text{IB}}$		0.01	1	$\mu\text{A}$
Input offset voltage	Pin 7,8	$V_{\text{IO}}$		10		mV
Output current, Figure 9	Pin 9	$-I_O$	75	110	145	$\mu\text{A}$
	Pin 9	$+I_O$	88	120	165	$\mu\text{A}$
Short circuit forward transmittance	$I_{12} = f(V_{10-11})$ Pin 9	$Y_f$		1000		$\mu\text{A/V}$

Parameters	Test Conditions / Pin	Symbol	Min	Typ	Max	Unit
<b>Soft-start, Figures 7, 8</b>						
Starting current	$V_{10} = V_{13}$ Pin 10	$I_o$	20	30	50	$\mu\text{A}$
Final current	$V_{10} = -0.5 \text{ V}$ Pin 10	$I_O$	50	85	130	$\mu\text{A}$
Discharge current, restart pulse	Pin 10	$-I_O$	0.5	3	10	$\text{mA}$
<b>Load current detection, Figure 11</b>						
Input current voltage	$V_I = 300 \text{ mV}$ , $R_V = 1 \text{ K}\Omega$ Pin 11 Pin 11	$I_I$ $I_I$	0 300		500 308	$\mu\text{A}$ $\mu\text{A}$
Input offset voltage	Pin 11	$V_{IO}$	-8		0	$\text{mV}$
Output open current	$V_I = 0 \text{ V}$ , $R_V = 1 \text{ K}\Omega$ Pin 12	$I_O$	1		4	$\mu\text{A}$
Output current	$V_I = 300 \text{ mV}$ , $R_V = 1 \text{ K}\Omega$ $V_{12} = V_{13}$ Pin 12	$I_O$	120	127	134	$\mu\text{A}$
Current transfer ratio	$\text{CTR} = \frac{I_{12}}{I_{11}}$ $I_{12} = 150 \mu\text{A}$ Pin 12/11 $I_{12} = 300 \mu\text{A}$ Pin 12/11	CTR CTR		$0.44 \pm 5\%$ $0.42 \pm 6\%$		
Temperature coefficient of current transfer ratio	Pin 12/11	TC		0.2		$^{\circ}/_{00}\text{K}$



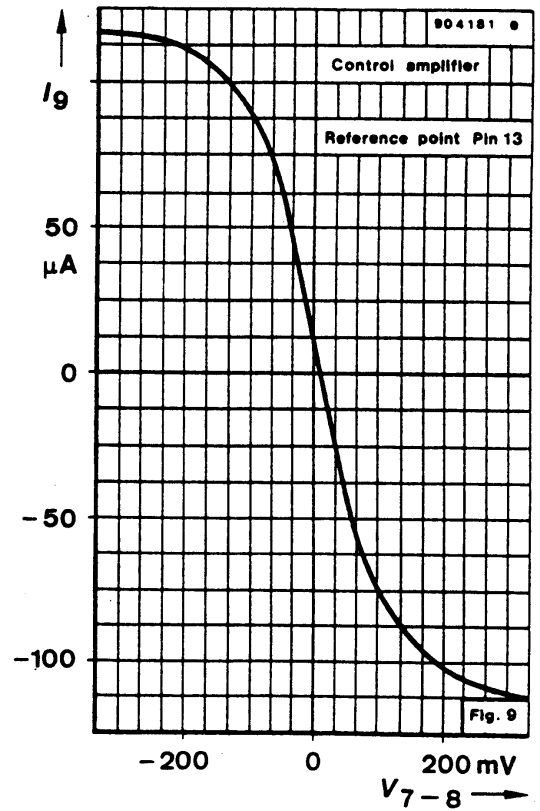
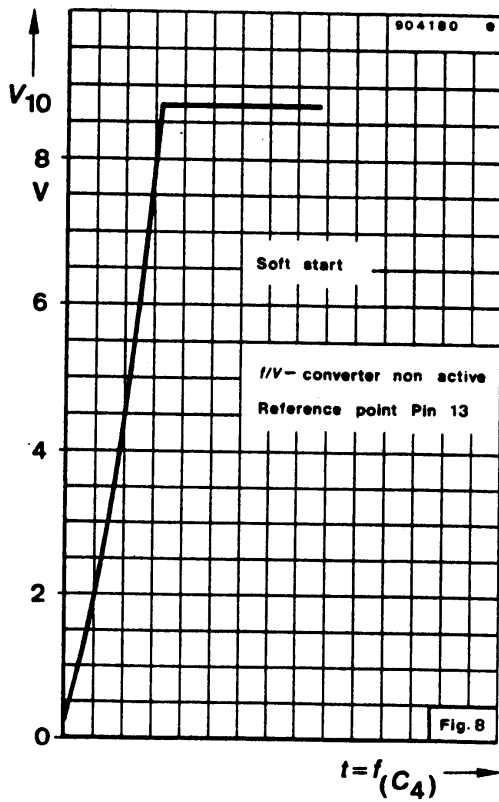
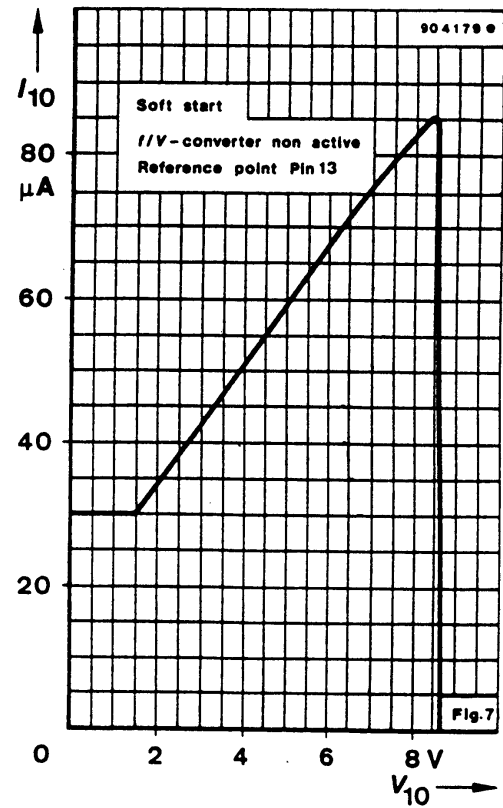
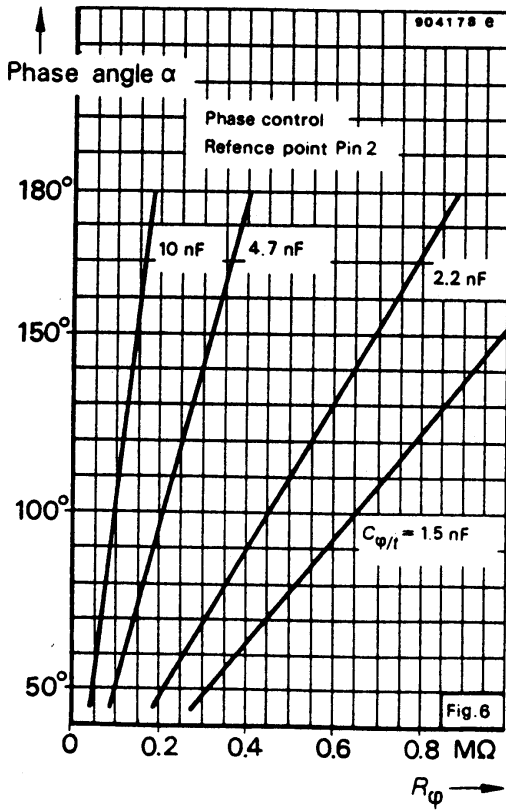

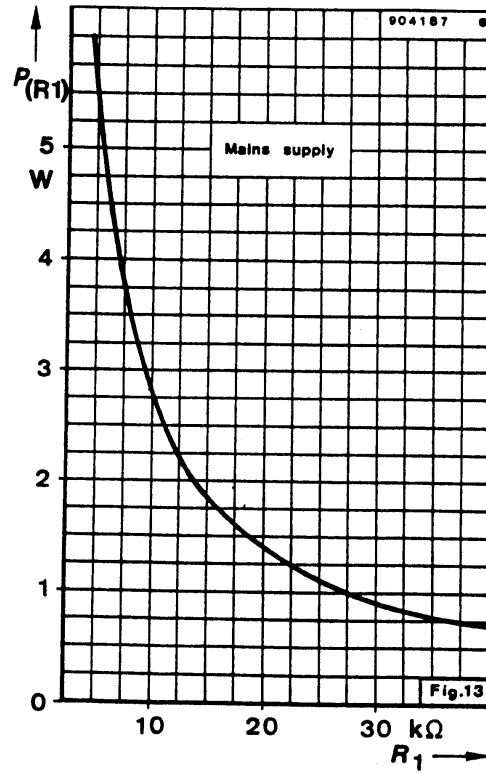
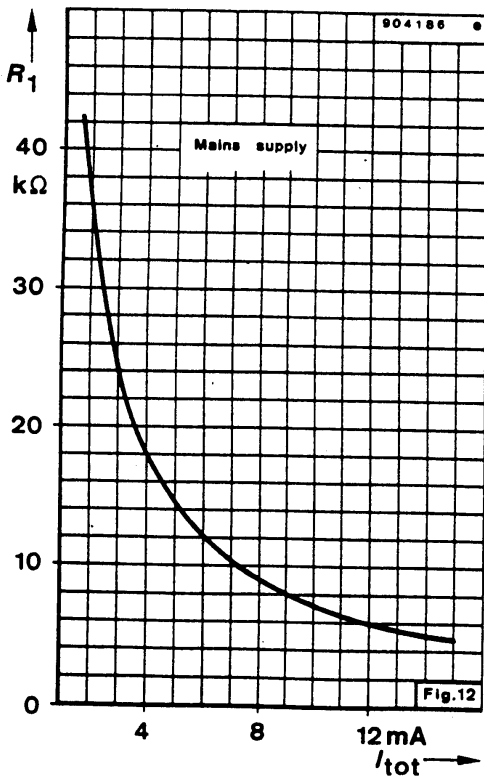
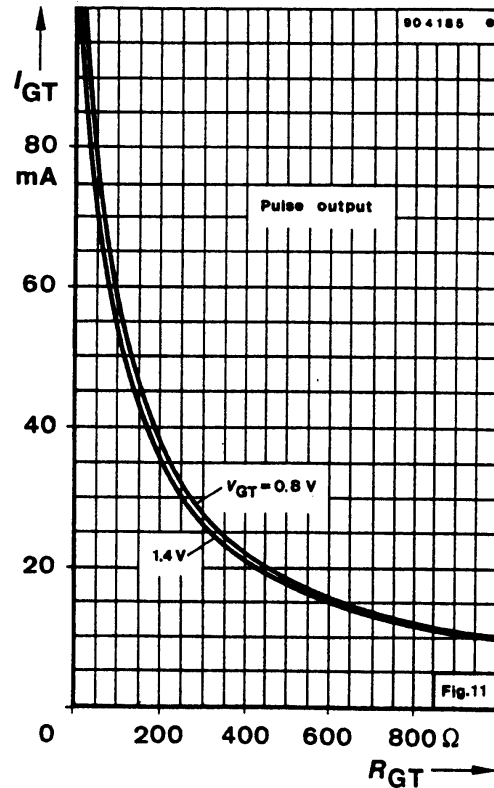
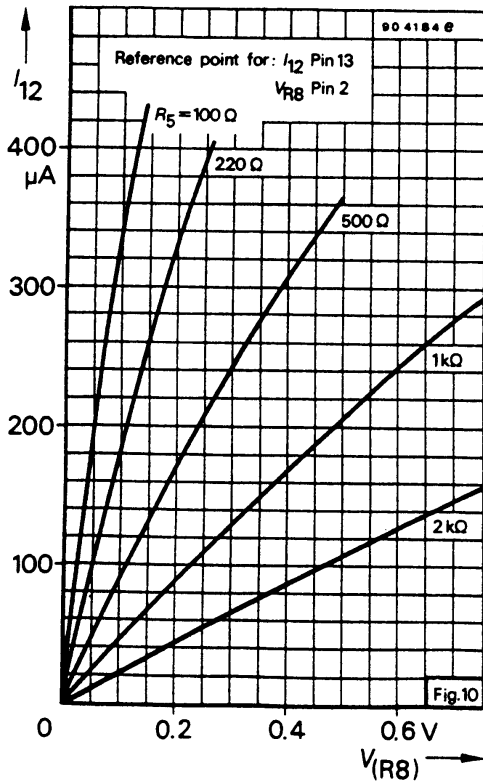

### Design calculations

The following equations can be used for the evaluation of the series resistor  $R_1$  for worst case conditions:

$$R_{1\max} = 0.9 \cdot \frac{V_{M\min} - V_{S\max}}{2 I_{\text{tot}}}$$

$$R_{1\min} = \frac{V_{M\max} - V_{S\min}}{2 I_{S\max}}$$

$$P(R_{1\max}) = \frac{(V_{M\max} - V_{S\min})^2}{2 R_1}$$

where:

$V_M$  = Mains voltage 220 V

$V_S$  = Supply voltage on Pin 4

$I_{\text{tot}}$  = Total DC current requirement of the circuit  
 $= I_{S\max} + I_p + I_x$

$I_{S\max}$  = Current requirement of the IC in mA

$I_p$  = Average current requirement of the triggering pulses

$I_x$  = Current requirement of other peripheral components

$R_1$  can be easily evaluated from Figures 12 – 14

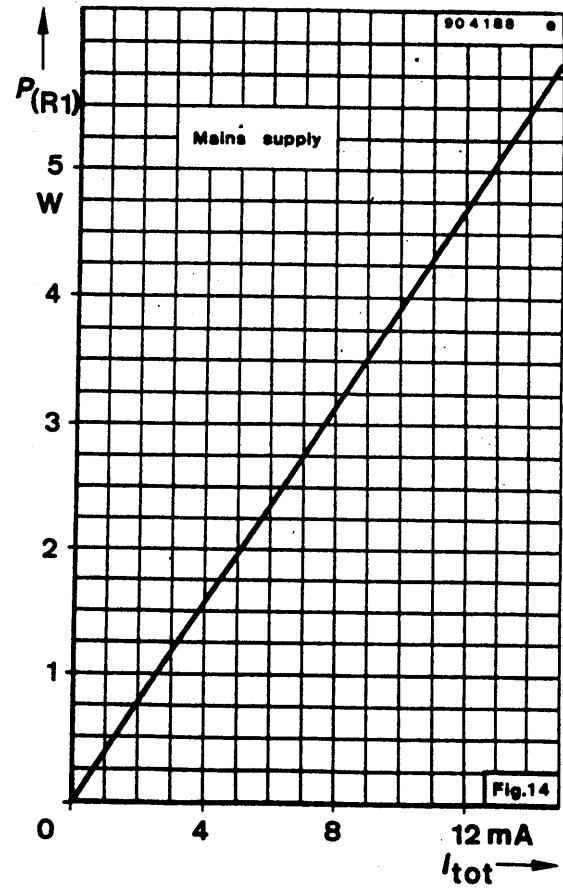

### Applications

In contrast to simple speed controller, the circuits shown in Figures 15 and 16, react to the load dependent speed drop in which the magnitude of the load current acts on the speed compensation.

For this purpose, the load current is measured by shunt resistor  $R_8$ . The voltage drop generates a current at Pin 11 dependent of  $R_5$ , which reflects in the specified current at the output of Pin 12.

Rated impedance of the output current at Pin 12 is represented through the coupling resistance  $R_7$  and the total impedance of the set point.

The integrated load current proportional signal at  $C_3$  effects in the same direction on the control input as the set point i.e., by the increase of load current follows an automatic increase of manipulated set point, so that a compensation of speed falls.

Compensation arrangement is influenced with resistance values i.e.  $R_5$  ( $= 100 \dots 5 \text{ k}\Omega$ ) and  $R_7$  ( $= 10 \text{ k}\Omega \dots 150 \text{ k}\Omega$ ) whereas the higher effect is achieved by increasing the value of  $R_7$  and decreasing  $R_5$ . Influence of compensation can be increased up to the value where the drive system (motor) starts to oscillate.

Dimensioning in the applications are with the drill machine of 700 W power.

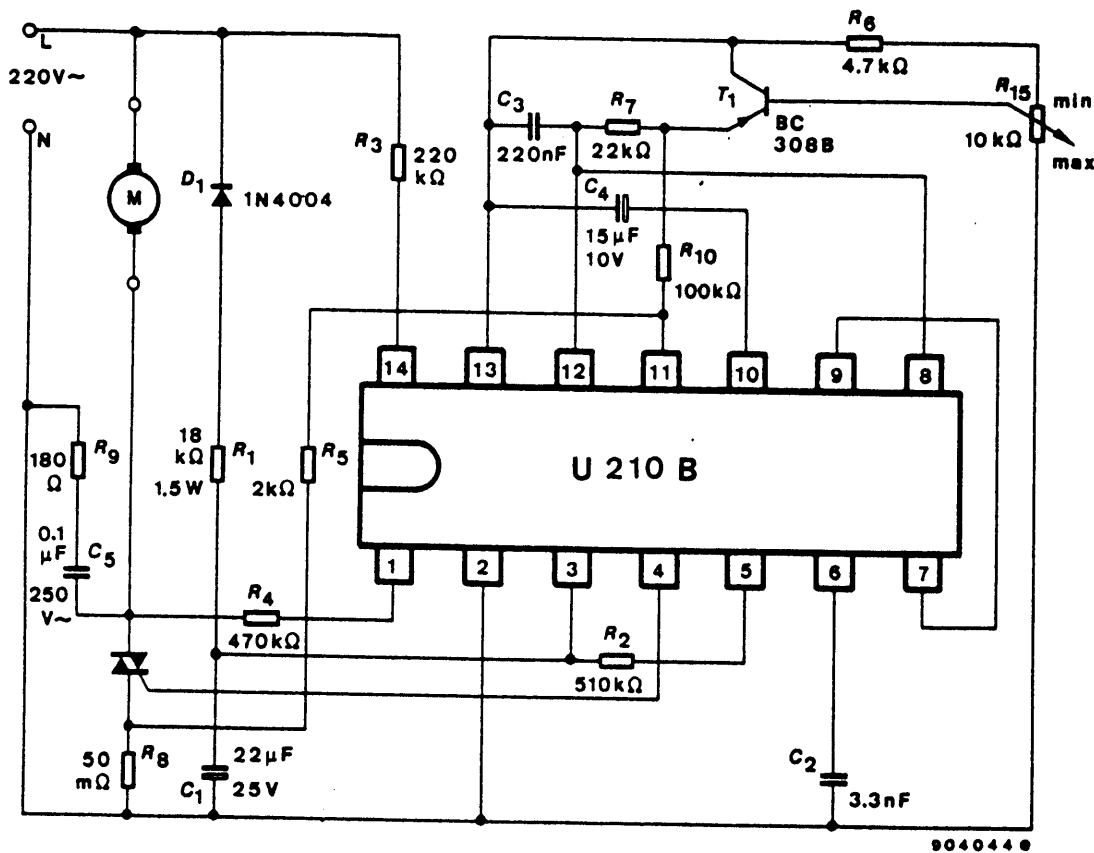

Figure 15 Speed control with load current compensation

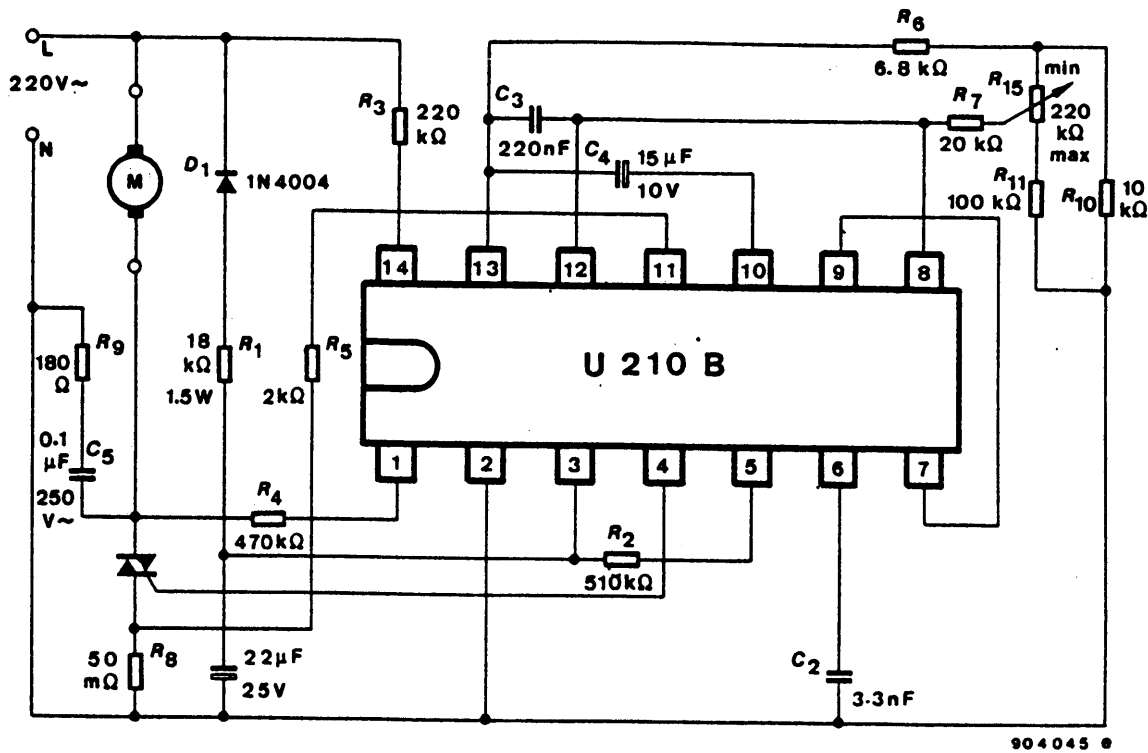

Figure 16 Speed control with load current compensation

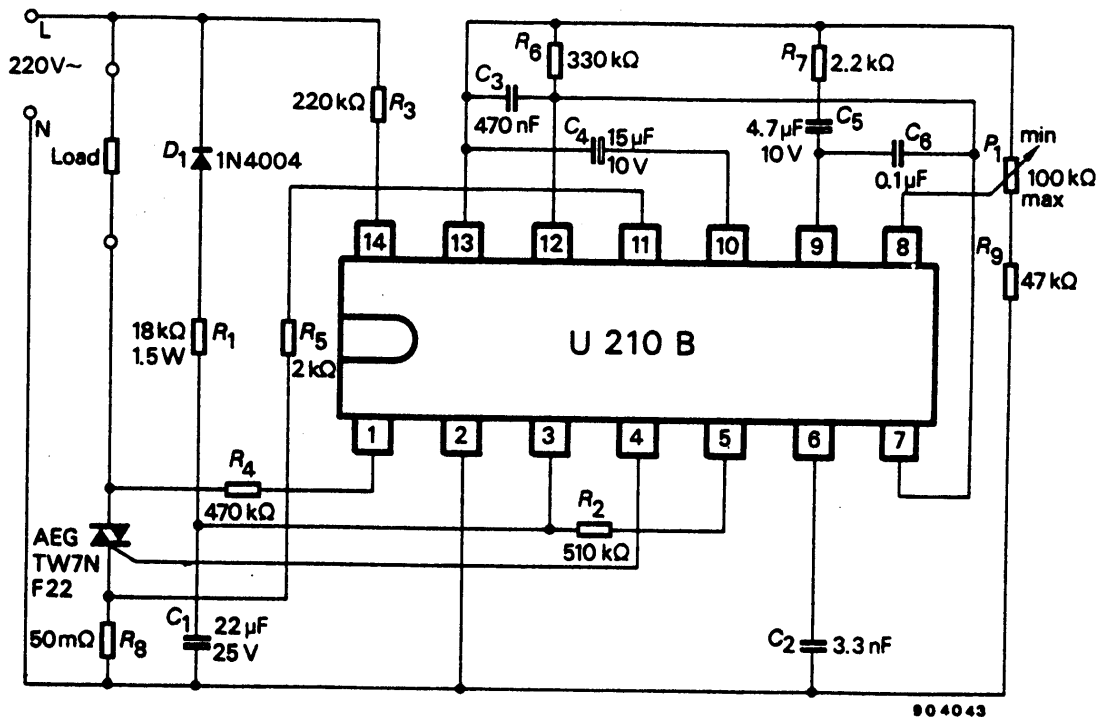
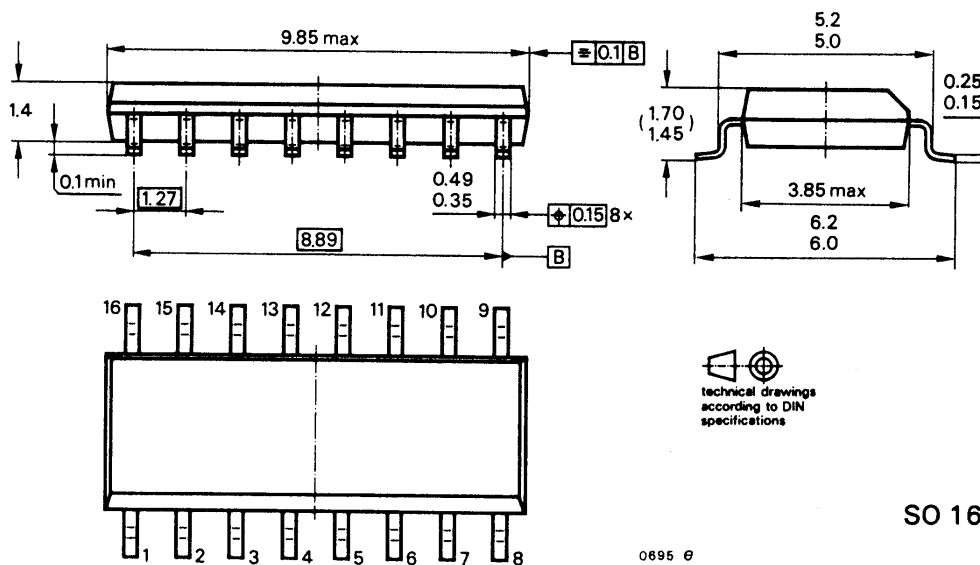
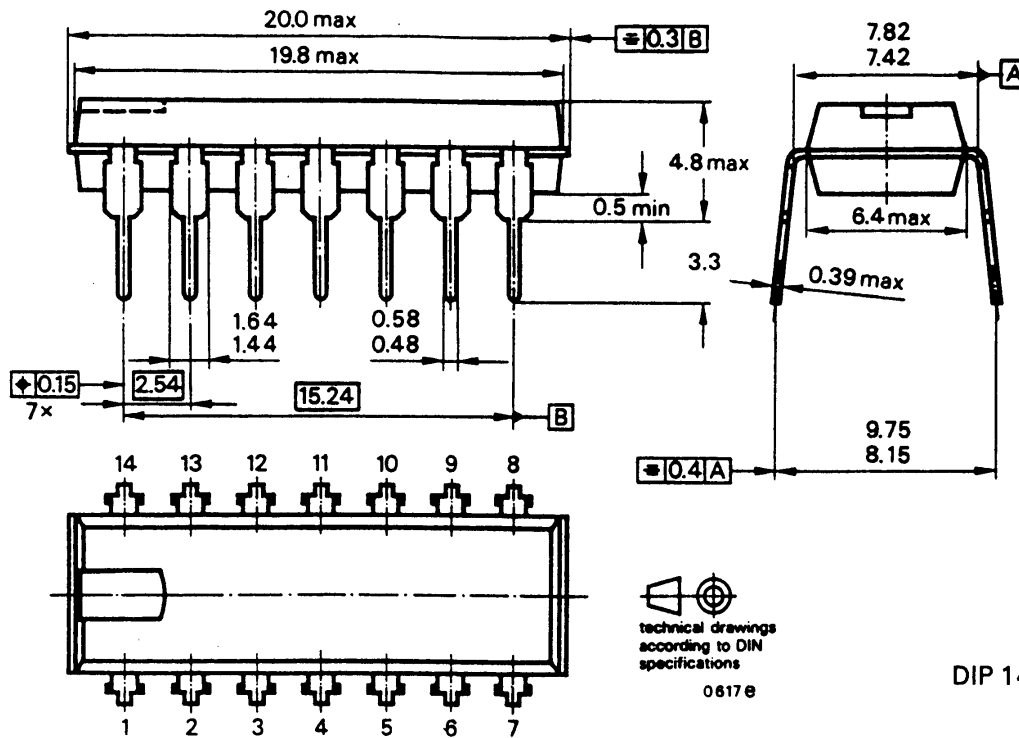

Figure 17 Load current regulation with soft start

Current regulation is achieved by the integrated operational amplifier as PI-controller (R7, C5, C6). Inverted input (Pin 7) of the operational amplifier is directly connected at C3 with load current proportional test signal (actual value).

Desired value is obtained with the help of potentiometer at Pin 8.

### Dimensions in mm



### OZONE DEPLETING SUBSTANCES POLICY STATEMENT

It is the policy of **TEMIC TELEFUNKEN microelectronic GmbH** to

1. Meet all present and future national and international statutory requirements and
2. Regularly and continuously improve the performance of our products, processes, distribution and operating systems with respect to their impact on the health and safety of our employees and the public, as well as their impact on the environment.

Of particular concern is the control or elimination of releases into the atmosphere of those substances which are known as ozone depleting substances (ODSs).

The Montreal Protocol (1987) and its London Amendments (1990) will soon severely restrict the use of ODSs and forbid their use within the next ten years. Various national and international initiatives are pressing for an earlier ban on these substances.

**TEMIC TELEFUNKEN microelectronic GmbH** semiconductor division has been able to use its policy of continuous improvements to eliminate the use of any ODSs listed in the following documents.

1. Annex A, B and list of transitional substances of the Montreal Protocol and the London Amendments respectively
2. Class I and II ozone depleting substances in the Clean Air Act Amendments of 1990 by the Environmental Protection Agency (EPA) in the USA and
3. Council Decision 88/540/EEC and 91/690/EEC Annex A, B and C (transitional substances) respectively.

**TEMIC** can certify that our semiconductors are not manufactured with and do not contain ozone depleting substances.

**We reserve the right to make changes without further notice to improve technical design.**

Parameters can vary in different applications. All operating parameters must be validated for each customer application by customer. Should Buyer use TEMIC products for any unintended or unauthorized application, Buyer shall indemnify TEMIC against all claims, costs, damages, and expenses, arising out of, directly or indirectly, any claim of personal damage, injury or death associated with such unintended or unauthorized use.

TEMIC TELEFUNKEN microelectronic GmbH, P.O.B. 3535, D-74025 Heilbronn, Germany  
Telephone: 49 (0)7131 67 2831, Fax Number: 49 (0)7131 67 2423